

Congratulations on becoming a String Player!

Here is a guide on everything that you will want to know about taking care of your instrument.

- * Start with your bow. Turn the button on the end to tighten the horsehair. Be careful not to overtighten the bow.



- * Avoid touching the hair with your fingers as skin oil prevents rosin from adhering to the bow hair.
- * Be sure to loosen the hair when you finish playing or the bow stick will warp.
- * Bows are fragile and should always be stored in the case not left on the music stand or on the floor.
- * Learning to tune your instrument is an art and your teacher will help. When tuning, turn the peg slowly and press it towards the pegbox. Using an electronic tuner will help find the right pitch.
- * Strings sometimes break, usually from being tuned too high or from friction. Friction occurs when the string is wound tightly against the wood sides.

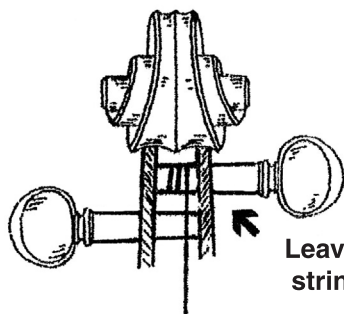

Leave gap between string and pegbox

- * If your instrument gets bumped, have your teacher or repair technician check the bridge. If anything breaks off of your instrument, save the piece for the repair person.
- * After playing, you may see white rosin dust on your instrument. If you wipe this off with a soft cloth the varnish will stay clean and shiny.
- * Always put your instrument & bow carefully away into its case or bag. Cellos and basses should be set down on their side. Avoid leaning them on a chair or upright in a corner.
- * Your string instrument needs to be protected. Be careful not to leave it in a car on cold or hot days as cracks or varnish damage could occur.
- * In the winter, low humidity can cause the wood to crack. Using a room humidifier or a dampit will help prevent problems.

MEYER *music*

*Quality instruments, supplies and music
backed by a tradition of outstanding
service, teaching and support*



meyer-music.com

GRAND RAPIDS
2855 Lake Eastbrook Blvd, 49512
(616) 975-1122

HOLLAND
675 East Lakewood, 49424
(616) 396-6583

MUSKEGON
1664 East Sternberg, 49444
(231) 865-7000